

Chapter XI

Symbolic Computation for DS-CDMA Code Acquisition Using First Order Logic

Ruo Ando

Keio University, Japan

Yoshiyasu Takefuji

Keio University, Japan

ABSTRACT

Code division multiple access (CDMA) is widely used because of its effectiveness to send multiple signal and confidentiality of career signal. We present a formulation of state-space problem of which solution is directed by redundant reasoning control method for semiheuristic and lightweight DS-CDMA code acquisition. The reasoning of the state-space problem provides us with the way to find a K bit synchronized sequence among K dephased sequences with less calculation cost, compared with serial search and matched filter. In this process, redundancy-restriction method, called weighting strategy, enhances the searching ability of FOL (first order logic) reasoning for the faster and lightweight code acquisition. The combination of weighting strategy and correlator enables us to achieve the peak-detection within $K/3$ times of calculating inner products and its measurement. Our system is evaluated by the reduced cost of proving state-space problem using weighting strategy and its robustness of using the proposal code acquisition framework. Experiment shows that the proposal method is robust if K/N sequences are grouped with N ranging from 3 to 5.

INTRODUCTION

Code division multiple access (CDMA) is widely used because of its effectiveness to send multiple

signals and confidentiality of career signal (Viterbi, 1979). Therefore, CDMA is an important technique for multimedia communication. Synchronization is an important task for telecommu-

nication, especially for CDMA. In this chapter, we propose a symbolic computation for direct sequence CDMA code acquisition using FOL (first order logic) applying this puzzle.

“the billiard balls and balance scale puzzle”

There are N billiard balls, $N - 1$ of which are identical in weight. The remaining ball—the odd one—has a different weight. We are not informed whether it is heavier or lighter. We have a balance scale for weighting the balls. Can we find which ball is the odd ball in $N/4$ weightings, and also find out whether it is lighter or heavier than the others? In the proposal system, this puzzle is formulated as state-space problem, which is solved by automated reasoning with some resolution strategies.

Direct Sequence—Code Division Multiple Access (DS-CDMA)

Since 1990, as the usage of cellular phone has expanded, the market of wireless communication has been increased dramatically. Among many wireless communication systems, direct sequence code division multiple access is applied to represent low bandwidth wireless communication devices, such as cellular phones. In CDMA, all users send signals in the same bandwidth, simultaneously, with the unique code assigned to each terminal. Every user can coexist and transmit at the same time with smaller interface compared with TDMA and FDMA (Duel-Hallen, Holtzman, & Zvonar, 1995). This multiple-access system protects users from interference and jamming. These advantages are possible since the cross-correlations between the code of target user and one of the other users are small, while pseudonoise has a maximal value repeating itself every period. The receiver can decode information of each user when the code acquisition is completed, which means that we can detect the point where the correlation

between the received signal and unique code in each terminal has maximal value. The perfect synchronization is an important task in any sort of telecommunication. Particularly in CDMA, the unique sequence must be synchronized precisely to the received signal. Unless a maximal output from the correlator is not acquired, each user in CDMA system cannot get the information.

PN Sequence

As we discussed in the previous section, the pseudonoise plays an important role in the simultaneous usage of the same bandwidth. To achieve the immunity of interference, jamming, and radio multipath fading, the assigned code must have these properties:

- **Balance property:** Relative frequencies of 0 and 1 are each $1/2$. Run property: run lengths of zeros and ones are as expected in a Bernoulli sequence.
- **Shift property:** If the random sequence is shifted by any nonzero number of elements, the resulting sequence will have an equal number of agreements and disagreements with the original sequence. The m -sequence has the balance, run, and shift properties. The m sequences are almost ideal when viewed in terms of their autocorrelation function.

Proposed Method

In this chapter, we formulate the state-space problem for DS-CDMA code acquisition. Typical state space decides if a state is reachable from another state or finds the shortest path between two states. We begin with the initial state and apply a kind of transition axiom to pass from one solvable state to another. In our model, the solution of the problem provides the way of code acquisition of PN sequences, of which properties are the balance, run and shift property.

Figure 1. PN sequence

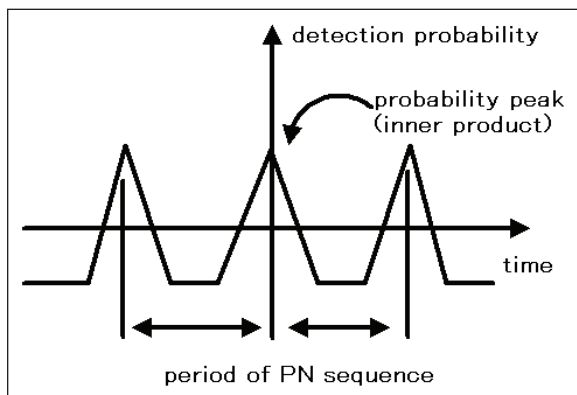

Formulation

In this chapter, we apply automated reasoning for the formulation of DS-CDMA code acquisition. From the beginning of the 1960s, automated reasoning has been improved with puzzles, mainly represented as state-space problem. The famous state-space problems that can be solved by automated reasoning method are “the checkerboard and dominoes puzzle,” “the missionaries and cannibals puzzle,” and “the billiard balls and balance scale puzzle.” Among state-space problem, concerning DS-CDMA code acquisition, the billiard balls and balance scale puzzle is applied.

There are N billiard balls, $N - 1$, of which are identical in weight. The remaining ball the odd one has a different weight. We are not informed whether it is heavier or lighter. We have a balance scale for weighting the balls. Can we find which ball is the odd ball in $N/4$ weightings, and also find out whether it is lighter or heavier than the others?

The solution of this puzzle assumes that finding the odd ball, that is, detecting synchronized sequence, can be achieved in $N/4$ weightings.

Compared with serial search and matched filter (Mustapha & Ormondroyd, 1999), the proposal method based on this puzzle is lightweight. The key of formulation of the puzzle is that, from the properties of PN sequences discussed in section 1.2, the $N - 1$ sequences excluding the synchronized one could be represented as “the same weight.” Owing to the shift property of PN sequences, the result of inner product calculation is not changed if we add some sequences that are not synchronized.

The notion of state is the point of this puzzle. The transition axioms to pass from one achievable state to the other one are used. According to this puzzle, the sequences are classified into “standard,” “heavy or standard,” “light or standard,” or “heavy or light or standard.” In the initial state, all N sequences are recognized as heavy or light or standard. And then, putting these conditions together, we can formulate the DS-CDMA code acquisition as follows:

There are N sequences, including synchronized sequence of which auto-correlation is -1 or 1 . You are not told whether its correlation is 1 or -1 . Can you find which sequence is the synchronized one in $N/4$ weightings, and also find out whether its class is “heavy or standard” or “light or standard”?

On the process of reasoning, many generated states are solvable, of which any transition of the state is not to lead goals, is deleted. The number of outcomes that can occur when there are n weightings remaining is 3^n . If the number of possibilities for the odd ball is greater than the number of outcomes, then the situation is hopeless; that is, the state is unsolvable. The other fact necessary for applying the transition axiom is there are three cases after balancing (calculating inner product).

Let the sequences in initial state that is heavy or light or standard be $XHLS$, the sequences picked up for multiplier $YHLS$, the sequences picked up for multiplicand $ZHLS$, and let the number of users be M .

Case 1: “scale balanced” with inner product around N/M . All the sequences calculated are standard weight (unsynchronized).

Thus, resulting state is:

$$\begin{aligned} HLS &= XHLS - (YHLS + ZHLS) \\ HS &= XHS - (YHS + ZHS) \\ LS &= XLS - (YLS + ZLS) \end{aligned}$$

The number of standard class sequences in the resulting state:

$$S = XS + YHLS + ZHLS * YHS + ZHS + YLS + ZLS$$

Case 2: “scale tips left” with inner product around $-N/M$. Thus, resulting state is:

$$\begin{aligned} HLS &= XHLS = 0 \\ HS &= XHS - (YHS + ZHS) \\ LS &= XLS - (YLS + ZLS) \end{aligned}$$

The number of standard class sequences in the resulting state:

$$\begin{aligned} S &= XS + ZLS + YHS + (XHLS - YHLS - ZHLS) \\ &+ (XHS - YHS - ZHS) + (XLS - YLS - ZLS) \end{aligned}$$

Case 3: “scale tips right” with inner product around 0.

Thus, resulting state is:

$$\begin{aligned} HLS &= XHLS = 0 \\ HS &= XHS - (YHS + ZHS) \\ LS &= XLS - (YLS + ZLS) \end{aligned}$$

The number of standard class sequences in the resulting state:

$$\begin{aligned} S &= XS + ZLS + YHS + (XHLS - YHLS - ZHLS) \\ &+ (XHS - YHS - ZHS) + (XLS - YLS - ZLS) \end{aligned}$$

We apply the inference rule of hyperresolution as the approach for the reasoning program to know that this problem has been solved. Also, we choose the set of support strategy discussed in the following section. The clauses placed in the set of support are the clauses that give the initial state and the one that denies that the initial state is solvable. The state with which the initial state is generated a proof by contradiction is found is three. In one, no weightings remain, $N - 1$ of billiard balls are known to be of standard weight, and one belongs to HS class. A second state is the counterpart to this one but with the N^{th} ball known to be in LS class. A final state is that all N sequences are known to be of standard weight, which means this puzzle is not solvable. In the process of resolution, the third process turns out be useful although in this state, the problem is incorrectly given.

ATP STRATEGY

On the usage of OTTER, the automated reasoning program, a strategy is available to prevent the reasoning program from wandering through the examination of various combinations of facts, the vast number of paths of inquiry. There exist some categories of strategies in OTTER, ordering strategy, restriction strategy, and pruning

strategy. Without these directions, the program would seldom reach the solution generating too many resolutions and clauses, even for the simplest problems.

Set of Support Strategy

Set of support was introduced by Wos et al. (Wos, Robinson, & Carson, 1965). If the clause T is retrieved from S , SOS is possible with the satisfiability of $S - T$. Set of support strategy enables the researcher to select one clause characterizing the searching to be placed in the initializing list called SOS . For the searching to be feasible and more effective, the resolution of more than one clause not in SOS is inhibited in order to prevent the prover going into an abundant searching place. Figure 2 shows the resolution process in set of support strategy, where $S = \{P \text{ and } Q \text{ and } R, P \text{ and } R, Q \text{ and } R, R\}$. The restriction imposes the reasoning so that the program does not apply an inference rule to a set of clauses that are not the complement of set of support.

Hyperresolution

In *generating encoder*, we apply the inference rule called *hyperresolution*, which is a kind of resolution that can do resolutions at once compared with several steps in another rule. For hyperresolution (Wos, 1998), these must be the negative or mixed clause with the remaining clauses equal to the number of literals in the negative or mixed clause. Figure 3 shows the framework of hyperresolution. The positive clause is described as satellites, the negative clause nucleus. “Hyper” means that in this resolution more process has occurred than another resolution such as binary resolution.

In this chapter, we utilize the open source software organized techniques for theorem proving and effective research (OTTER). OTTER is a first order logic prover, of which statements written in prolog-style format with equality featuring the inference rules binary resolution, hyperresolution, and binary paramodulation. This prover has autonomous mode where the user inputs a set of clauses that OTTER does a syntactic analysis. OTTER 3.3 was released on August 2003, similar to

Figure 2. Set of support

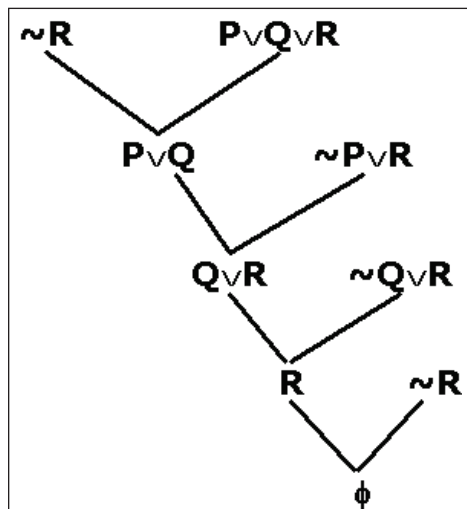
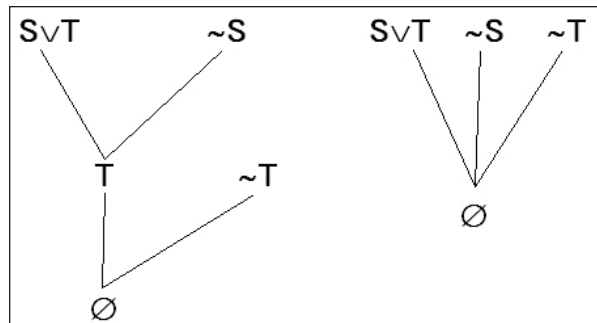

Figure 3. Hyperresolution



AURA and LMA/ITP theorem provers associated with Argonne National Laboratory. The problem in this chapter originated from “the billiard balls and balance scale puzzle” is solved on OTTER with formulation for CDMA code acquisition. In the next section, we discuss the statistics and CPU utilization of the process of proof.

Weighting Strategy

In contrast to the restriction strategies, which block reasoning path to apply inference rules to many kinds of subsets of clauses, a direction (ordering) strategy dictates what to set focus on next. Among these strategies, we apply weighting strategy. With this direction strategy, we can assign priorities to terms, clauses, and concepts

that make it possible to reflect the knowledge and intuition about how a reasoning program should proceed. Weighting strategy, opposite of the restriction strategy called set of support, can be used complementarily. In the situation where the set of support strategy is adopted, the remaining clauses can be processed to complete the application of various inference rules. After the clauses assigned to set of support have been the focus of attention, we can choose among the new clauses generated and retained for the following various kinds of inference application. With weighting, you can supply various criteria for defining interests and for defining complex information. After the input clauses have been the focus of attention, the choice is made from among the new clauses, those clauses that have been generated and retained

Table 1. 16 sequences (16 bit length)

clauses given	5625
clauses generated	21696
demod & eval rewrites	178926
clauses forward subsumed	16084
clauses kept	5604
empty clauses	16
user CPU time	109.23
system CPU time	.33

because they represent new information that is deemed acceptable.

NUMERIC RESULT

Evaluation of Weighting Strategy

The performance measurements were collected on a Linux kernel 2.4.8-13 host computer system using Pentium III 700 MHz with 512K RAM.

In contrast to the restriction strategies, which block a reasoning path to apply an inference rules to many kinds of subsets of clauses, a direction (ordering) strategy dictates what to set focus on next. Among these strategies, we apply weighting strategy. With this direction strategy, we can

assign priorities to terms, clauses, and concepts that make it possible to reflect the knowledge and intuition about how a reasoning program should proceed. Weighting strategy, opposite to the restriction strategy called set of support, can be used complementarily. In the situation where the set of support strategy is adopted, the remaining clauses can be processed to complete the application of various inference rules. After the clauses assigned to set of support have been the focus of attention, we can choose among the new clauses generated and retained for the following various kinds of inference application. With weighting, you can supply various criteria for defining interests and for defining complex information. After the input clauses have been the focus of attention, the choice is made from among the new clauses,

Table 2. 32 sequences (32 bit length)

clauses given	1773
clauses generated	69478
demod & eval rewrites	573078
clauses forward subsumed	51692
clauses kept	17772
empty clauses	28
user CPU time	1709.7
system CPU time	1.75

Table 3. 12 sequences (12 bit length)

clauses given	153
clauses generated	444
demod & eval rewrites	3630
clauses forward subsumed	288
clauses kept	152
empty clauses	8
user CPU time	14.7
system CPU time	0.02

Table 4. 16 sequences (12-bit length) with weighting

clauses given	148
clauses generated	432
demod & eval rewrites	3531
clauses forward subsumed	280
clauses kept	147
empty clauses	8
user CPU time	14.36
system CPU time	0.02

Figure 4. 3 user CDMA model

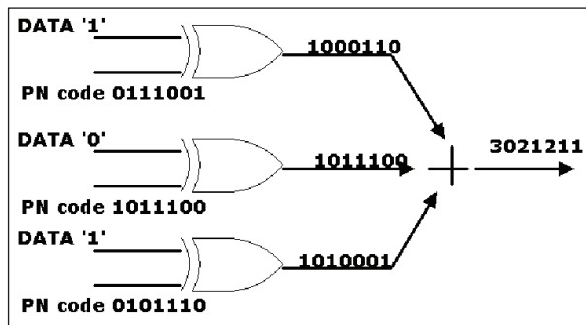

those clauses that have been generated and retained because they represent new information that is deemed acceptable.

Table 1 and 2 show the results of solving problems with each 16 and 32 sequences. It does not show liner increase, which means some kinds of resolution strategy is necessary according to the kind of PN sequences.

Table 3 and 4 shows the result of solving the problem with 12-bit sequences. In Table 4, weighting strategy is enabled. Experiments show that weighting is effective to reduce redundant clause generation, for faster problem solving.

Results of Inner Products Calculation

As we discussed before, the proposal system provides the cost reduction of DS-CDMA code

acquisition. In our model, we can find the synchronized PN sequence among N sequences in N/K ($K = 2, 3, 4$) times of inner product calculation. In the experiment, we pick up 128-bit PN sequences and 3 user models shown in Figure 4. To make this technique more lightweight, we grouped 4 and 8 sequences. According to the properties of PN sequences discussed in previously, it is expected that detection probability is not changed if several 0/1 sequences are added to one.

Table 5 lists the inner product of each user. In this 3-user model, the value 40 is set as threshold. Experiments show that the proposal method is effective because the average of inner product is around 40. However, several values are over 40 in table 5 (8 sequences * 16 uses). Table 6 lists the result in 4 sequences*32 users. It is expected to be better that we group more than 32 groups by adding each 4 sequences.

Table 5. 16 groups of 8 users

□	USER1	USER2	USER3
Synchronized (including peak)	-44	-52	-36
Another (average)	18.7	19.87	17.73

Table 6. 32 groups of 4 users

□	USER1	USER2	USER3
Synchronized (including peak)	-78	-46	-70
Another (average)	9.29	7.8	11.8

To put all things together, the proposal method can acquire the code of N sequences in where T is times of calculating inner product; L is the number of groups.

CONCLUSION

We have presented the formulation of state-space problem of which solution is directed by redundant reasoning control method for the heuristic and lightweight DS-CDMA code acquisition. The reasoning of the state-space problem provides us with the way to find a K -bit synchronized sequence among K -dephased sequences with less calculation cost compared with serial search and matched filter. In this process, redundancy restriction method, called weighting strategy, enhances the searching ability of first order logic (FOL) reasoning for the faster and lightweight code acquisition. The combination of weighting strategy and correlator enables us to achieve the peak-detection within $K/3$ times of calculating inner products and its measurement. Our system is evaluated by the reduced cost of proving state-space problem using weighting strategy and its robustness of using the proposal code acquisition framework. Experiment shows that the proposal

method is robust if K/N sequences are grouped with N ranging from 3 to 5.

REFERENCE

- Duel-Hallen, A., Holtzman, J., & Zvonar, Z. (1995). Advantages of CDMA and spread spectrum techniques over FDMA and TDMA in cellular mobile radio applications. *IEEE Personal Communications Magazine*
- Gilhousen, K., Jacobs, I., Padovani, R., Viterbi, A., Weaver, L., & Wheatley, C. (1995). On the capacity of a cellular CDMA system. *IEEE Trans. on Vehicular Technology Multiuser detection for CDMA systems*.
- Jung, P., Baier, P., & Steil, A. (1992). *IEEE Trans. on Vehicular Technology*.
- Keshavarzian, A. & Salehi, J. A. (2002). Optical orthogonal code acquisition in fiber-optic CDMA systems via the simple serial-search method. *IEEE Transaction on Communications*, 50(3).
- Kohno, R., Meidan, R., & Milstein, L. (1995). Spread spectrum access methods for wireless communications. *IEEE Communication Magazine*.

Mustapha, M. M., & Ormondroyd, R. F. (1999). Performance of a serial-search synchronizer for fiber-based optical CDMA system in the presence of multi-user interference. *Proc.SPIE*, 3899, 297-306.

Mustapha, M. M., & Ormondroyd, R. F. (2000). Dual-threshold sequential detection code synchronization for an optical CDMA network in the presence if multi-user interference. *IEEE J.Lightwave Technol*, 18, 1742-1748.

Viterbi, A. J. (1979). Spread spectrum communications—myths and realities. *IEEE Communication Magazine*.

Wos, L. (1998). The problem of explaining the disparate performance of hyperresolution and paramodulation. *J. Autom. Reasoning*, 4(2), 215-219.

Wos, L., Robinson, G., & Carson, D. (1965). Efficiency and completeness of the set of support strategy in theorem proving. *J. ACM*, 536-541.